

SECTION III

FORD

TSX SERIES

TRACTOR

Carbureters



MARVEL-SCHEBLER PRODUCTS DIVISION,

BORG-WARNER CORPORATION

DECATUR, ILLINOIS, U. S. A.

Warranty

Marvel-Schebler Products Division, Borg-Warner Corporation, warrant its carbureters against defects in material and workmanship for a period of ninety days. Defective merchandise will be replaced without charge but labor charges incurred in the removal, disassembly or reinstallation of such products will not be allowed. No merchandise can be returned without written permission from the factory, transportation charges must be prepaid. The factory shall be the sole judge of defects in products returned.

A ten per cent handling charge will be made for all merchandise returned that is not defective. All prices are subject to change without notice, and we reserve the right to limit quantities and to make partial shipments unless specifically instructed otherwise. The obligation of the company under this warranty is limited to replacing at the factory, any complete units or parts thereof which shall be returned and which our examination shall disclose to have been defective.

Introduction...

This section of the master manual is an individual parts catalog of all service parts for Marvel-Schebler carbureters listed on the identification charts. The catalog is divided into groups of carbureters; each group containing an identification chart, an exploded drawing of a composite carbureter, and a parts list. Each part in the illustration bears a reference number which keys together the illustration and parts list.

NOTE: The illustration does not represent any specific carbureter within a series, but is typical of all of them. All parts that look different are shown adjacent to the part of the basic carbureter that they replace.

TO USE THE CATALOG

- (1) Locate the group which contains the carbureter in question by referring to the identification charts.
- (2) Visually locate the part desired in the exploded drawing and note its reference number.
- (3) Turn to the parts list opposite the reference number of the part for its complete part name and part number.

FORD — TRACTOR CARBURETERS

ISSUED MARCH 1953

16740

Model Application	Engine	Carbureter Number	Fuel	Superseded by	Customer Part No.	◆ Repair Kit No.	§ Gasket Kit No.	Float Valve & Seat Assy
Tractor	9NA	TSX-33	Gasoline	TSX-241B	9N-9510-A	286-562	16-597	233-536
Industrial		TSX-38	Gasoline		2N-9510	286-562	16-597	233-536
Industrial		TSX-83	Gasoline		ONY-9510	286-940	16-597	233-536
Tractor		TSX-241A	Gasoline	TSX-241B	8N-9510	286-927	16-597	233-536
Tractor		TSX-241B	Gasoline		ED-8N-9510	286-562	16-597	233-536
Tractor		TSX-241C	Gasoline	TSX-241B	8N-9510	286-927	16-597	233-536
Tractor		TSX-420	Distillate		8NAN-9510	286-927	16-597	233-536
Tractor		TSX-428	Gasoline		EAE-9510-A	286-1010	16-675	233-536

◆ The repair kit includes the throttle shaft, float valve and seat assembly and the gasket kit.

§ The flange gasket can be supplied separately. Specify the carbureter number when ordering.

BASIC SUBASSEMBLIES

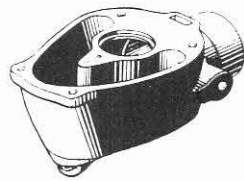

CARBURETER BODY ASSEMBLY

Carbureter Number	Marvel-Schebler Part Number	Ford Part Number
TSX-33	10-1973	9N-9511
TSX-38	10-3312	
TSX-83	10-2133	
TSX-241A	10-3175	
TSX-241B	10-3442	
TSX-241C	10-3575	
TSX-420	10-3416	
TSX-428	10-3612	9N-9511-A

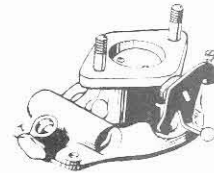

THROTTLE BODY & SHAFT ASSEMBLY

Carbureter Number	Marvel-Schebler Part Number	Ford Part Number
TSX-33	227-627	9N-9515
TSX-38	227-627	9N-9515
TSX-83	227-710	
TSX-241A	227-1131	
TSX-241B	227-627	9N-9515
TSX-241C	227-1283	
TSX-420	227-1131	
TSX-428	227-1293	EAE-9515-A

Ref. No.	Part Name	Marvel-Schebler Part Number	Ford Part Number	TSX-33	TSX-38	TSX-83	TSX-241A	TSX-241B	TSX-241C	TSX-420	TSX-428
1	Body Assy — Carbureter	(See Basic Subassembly)		1	1	1	1	1	1	1	1
2	Shaft & Lever Assy — Throttle	13-778	9N-9581-A	1	1	1	1	1	1	1	1
2A	Shaft & Lever Assy — Throttle	13-801	ONY-9581	—	—	1	—	—	—	—	—
2B	Shaft, Stop & Lever Assy — Throttle	13-1050	EAE-9581-A	—	—	—	—	—	—	—	1
3	Valve — Throttle (15°)	14-175 14-236	9N-9585-A	1	1	1	—	1	—	—	1
4	Screw — Throttle Stop (No. 8-32 x 3/4)	15-42	31093-S8	1	1	1	1	1	1	1	1
5	Screw — Idle Drilling (Headless, 1/4-20)	15-223	355305-S	—	—	1	—	—	—	—	—
6	Screw — Choke Swivel (No. 8-32 x 5/16)	15-285		—	—	1	—	—	—	—	—
7	Screw — Drill Plug, Nozzle Hole (No. 8-32)	15-409	357378-S	1	1	—	1	1	1	1	1
8	Screw & Lock Washer Assy — Throttle Body to Bowl (No. 12-24 x 5/8)	15-A82	9N-9973	4	4	4	4	4	4	4	4
9	Screw & Lock Washer Assy — Choke Valve (No. 4-40 x 1/4)	15-A91	355000-S19	2	2	2	2	2	2	2	2
10	Screw & Lock Washer Assy — Throttle Valve (No. 4-40 x 1/4)	15-A91	355000-S19	2	2	2	2	2	2	2	2
11	Gasket — Float Valve Seat	16-4	9N-9564	1	1	1	1	1	1	1	1

FORD — TRACTOR
TSX-33 to TSX-428

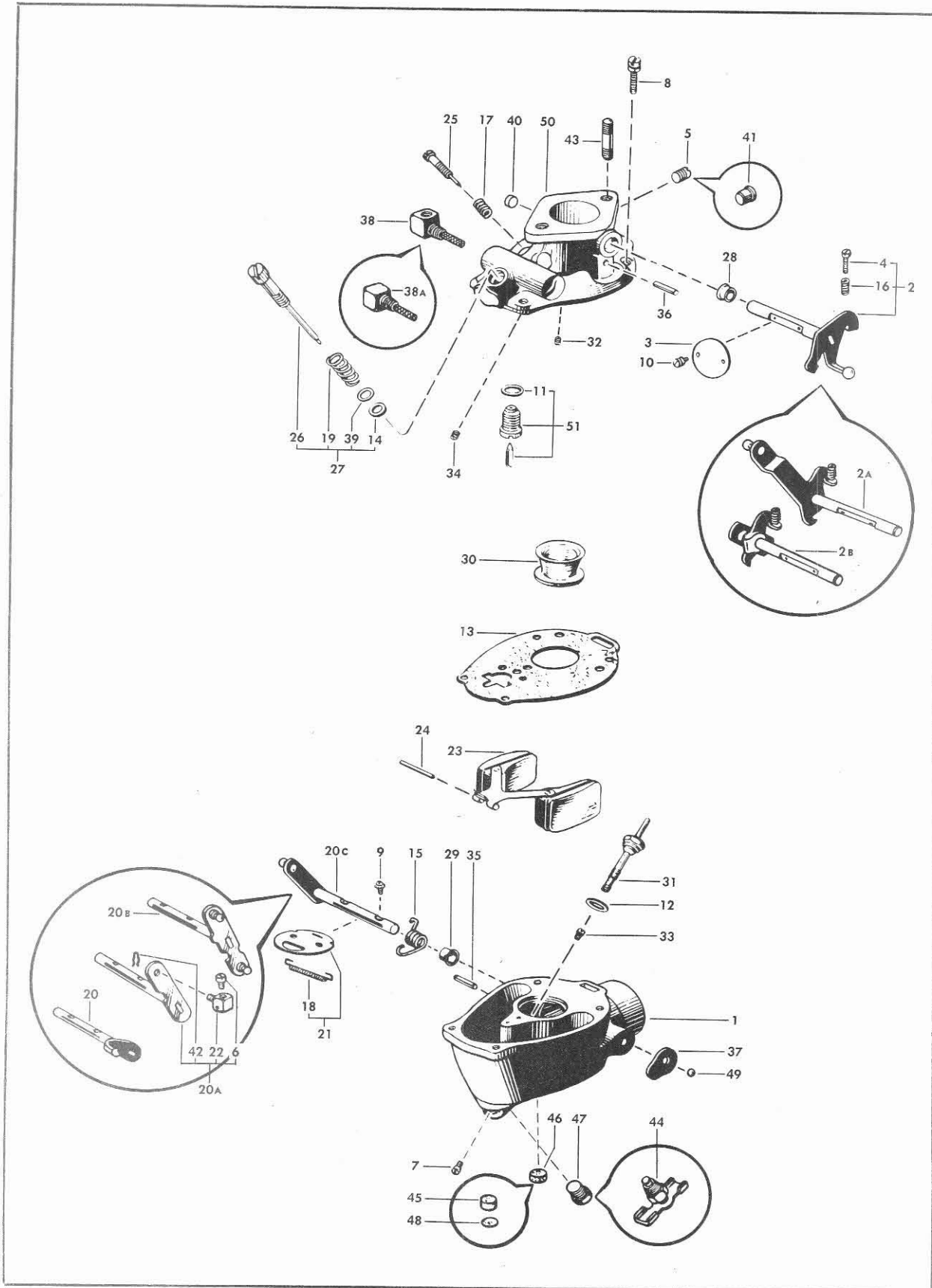

Marvel-Schebler Products Division, Borg-Warner Corporation, Decatur, Illinois, U. S. A.

Ref. No.	Part Name	Marvel-Schebler Part Number	Ford Part Number	TSX-33	TSX-38	TSX-83	TSX-241A	TSX-241B	TSX-241C	TSX-420	TSX-428
12	Gasket — Main Nozzle	16-28		1	1	1	1	1	1	1	1
		16-449	9N-9608	1	1	1	1	1	1	1	1
13	Gasket — Throttle Body to Bowl	16-80	9N-9519	1	1	1	1	1	1	1	1
14	Gasket — Power Adjusting Needle	16-491	9N-9563	1	1	1	1	1	1	1	1
15	Spring — Choke Return	24-188	9N-9539	1	1	1	1	1	1	1	1
		24-A40	9N-9539	1	1	1	1	1	1	1	1
16	Spring — Throttle Stop Screw	24-262	9N-9589	1	1	1	1	1	1	1	1
17	Spring — Idle Needle	24-340	9N-9578	1	1	1	1	1	1	1	1
18	Spring — Choke Valve Flapper	24-425	9N-9560	1	1	1	1	1	1	1	1
19	Spring — Power Adjusting Needle	24-A1	9N-9540-C	1	1	1	1	1	1	1	1
20	Shaft & Lever Assy — Choke	26-634	9N-9546	1	1	1	1	1	1	1	1
20A	Shaft & Lever Assy — Choke	26-645	ONY-9546	1	1	1	1	1	1	1	1
20B	Shaft & Lever Assy — Choke	26-676		1	1	1	1	1	1	1	1
20C	Shaft & Lever Assy — Choke	26-766	EAE-9546-A	1	1	1	1	1	1	1	1
21	Valve Assy — Choke	27-539	9N-9549	1	1	1	1	1	1	1	1
22	Swivel — Choke Lever	28-49	ONY-9555	1	1	1	1	1	1	1	1
23	Float & Lever Assy	30-600	9N-9550	1	1	1	1	1	1	1	1
24	Shaft — Float Lever	32-27	9N-9558	1	1	1	1	1	1	1	1
25	Needle — Idle Adjusting	45-33	9N-9541	1	1	1	1	1	1	1	1
26	Needle Assy — Power Adjusting	43-628	9N-9565-C	1	1	1	1	1	1	1	1
		43-632	9N-9565-C	1	1	1	1	1	1	1	1
27	Needle Assy — Power Adjusting (complete)	43-641		1	1	1	1	1	1	1	1
		43-642		1	1	1	1	1	1	1	1
28	Packing — Throttle Shaft	44-63	8N-9622	1	1	1	1	1	1	1	1
29	Packing — Choke Shaft	44-66	8N-9689	1	1	1	1	1	1	1	1
30	Venturi (11/16" Diameter Throat)	46-467	9N-9586	1	1	1	1	1	1	1	1
	(23/32" Diameter Throat)	46-476	9N-9586	1	1	1	1	1	1	1	1
31	Nozzle — Main	47-180	9N-9530	1	1	1	1	1	1	1	1
		47-270		1	1	1	1	1	1	1	1
32	Jet — Economizer	49-161	9N-9914	1	1	1	1	1	1	1	1
		49-349		1	1	1	1	1	1	1	1
33	Jet — Power	49-162	9N-9533	1	1	1	1	1	1	1	1
34	Jet — Idle	49-165	9N-9596	1	1	1	1	1	1	1	1
		49-345		1	1	1	1	1	1	1	1
35	Pin — Choke Stop	62-167	9N-9575	1	1	1	1	1	1	1	1
		62-196	9N-9690	1	1	1	1	1	1	1	1
36	Pin — Throttle Stop	62-167	9N-9575	1	1	1	1	1	1	1	1
37	Plate — Numbering	(Specify TSX Number)		1	1	1	1	1	1	1	1
38	Elbow & Screen Assy — Fuel Inlet	67-514	9N-9553	1	1	1	1	1	1	1	1
38A	Inlet & Screw Assy — Fuel	68-509	ONY-9553	1	1	1	1	1	1	1	1
39	Washer — Flat, Power Adjusting Needle	78-299	356211-S7-8	1	1	1	1	1	1	1	1
40	Cup — Throttle Shaft	80-169	8N-9941	1	1	1	1	1	1	1	1
41	Plug — Idle Drilling	80-171	8N-9974-B	1	1	1	1	1	1	1	1
42	Cotter — Hairpin (Choke Swivel)	82-16	ONY-9542	1	1	1	1	1	1	1	1
43	Stud — Flange	83-413	88371-S1-8	2	2	2	2	2	2	2	2
44	Cock — Drain	87-3A		1	1	1	1	1	1	1	1
45	Strainer — Fuel Drain	*95-40		1	1	1	1	1	1	1	1
46	Strainer — Fuel Drain	*95-78	9N-9694-B	1	1	1	1	1	1	1	1
47	Plug — Bowl Drain	99-7	358043-S7-8	1	1	1	1	1	1	1	1
48	Plug — Expansion, Bowl Drain	*179-35		1	1	1	1	1	1	1	1
49	Ball — Numbering Plate	206-36	9N-9567	1	1	1	1	1	1	1	1
50	Body & Shaft Assy — Throttle	(See Basic Subassembly)		1	1	1	1	1	1	1	1
51	Valve & Seat Assy — Float	233-536	9N-9564	1	1	1	1	1	1	1	1

* Production previous to July, 1947 used part number 95-40 with part number 179-35. These parts are not replaced with part number 95-78 but are still supplied for service.

SUPPLEMENT 1

**FORD
TSX SERIES**

TSX-500 to TSX-706

FORD — TRACTOR CARBURETERS

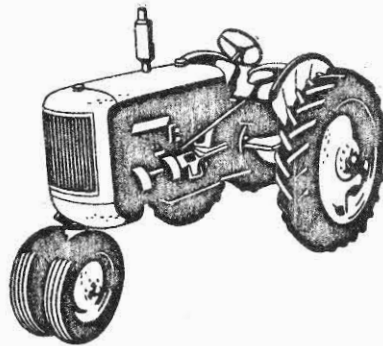

INSERT IN THE FORD SECTION OF THE MANUAL AFTER SECTION III

MARVEL-SCHEBLER PRODUCTS DIVISION

BORG-WARNER CORPORATION

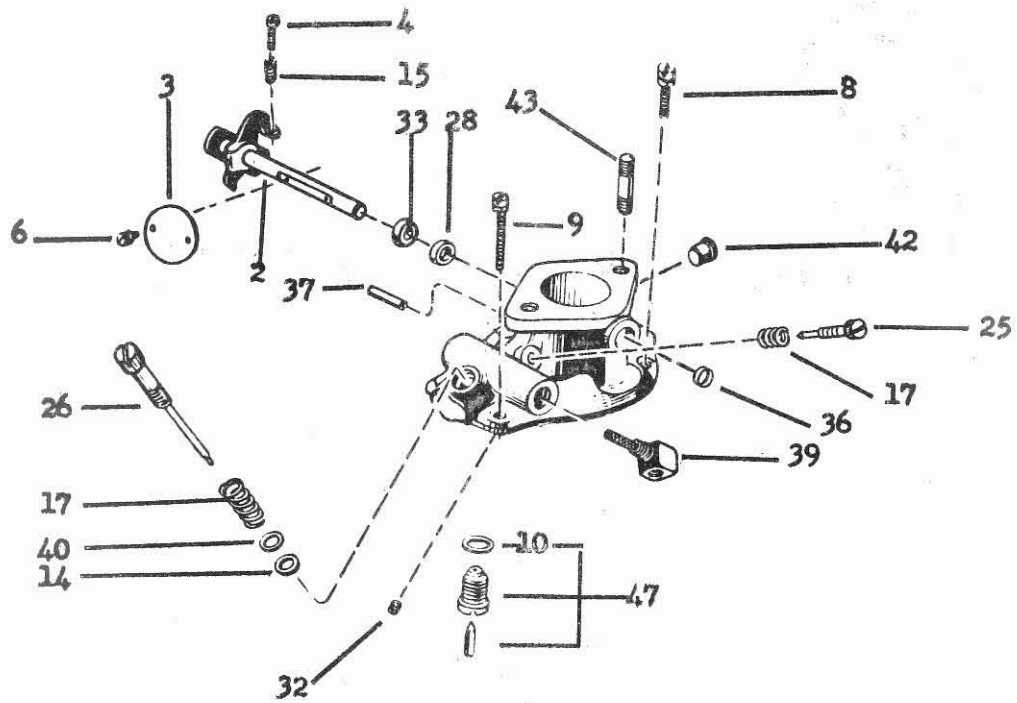

**FORD
TSX SERIES**

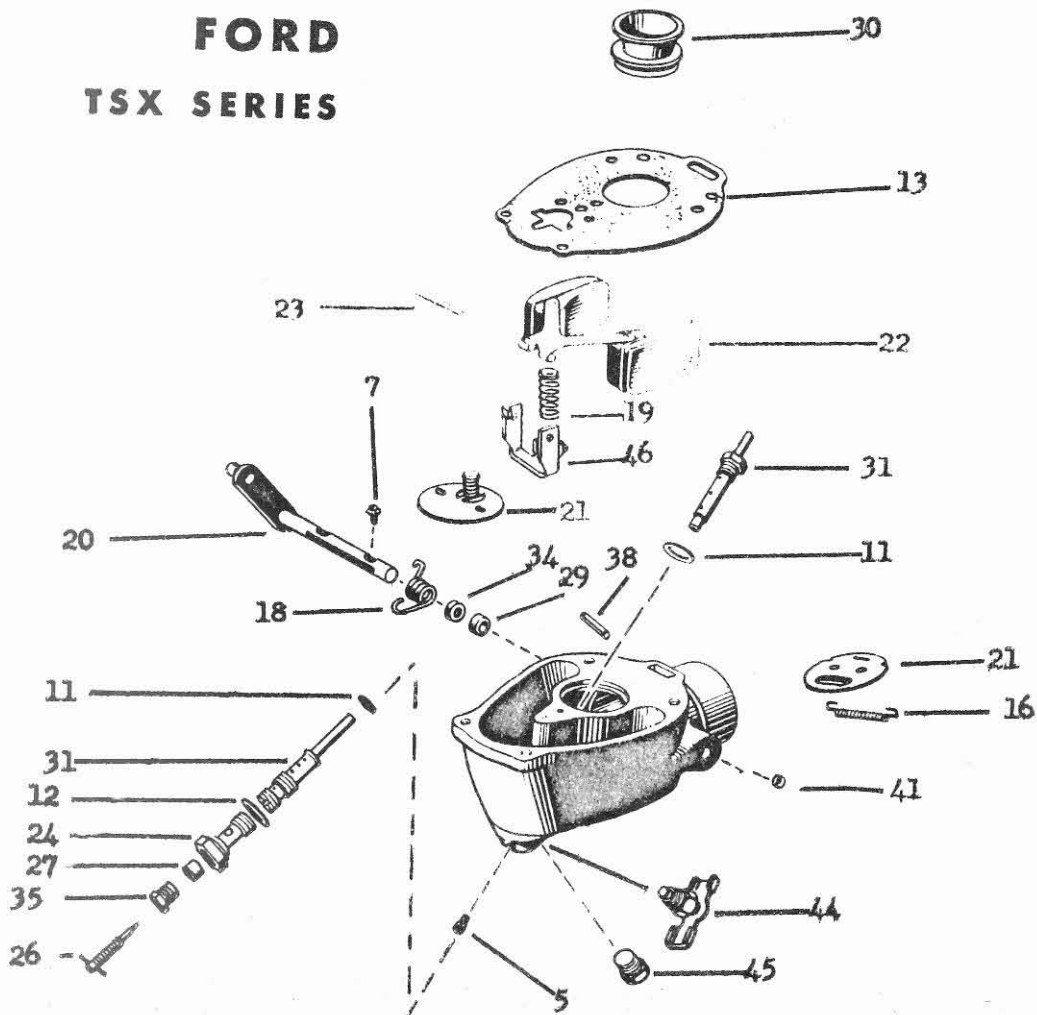

FORD — TRACTOR CARBURETERS

Model Application	Carbureter Number	Fuel	Superseded by	Customer Part No.	Repair Kit No.	Gasket Kit No.	Float Valve & Seat Assy
600 and 700..... POWER UNIT.....	TSX-500	Dist	- - - - -	EBD-9510-D	286-1011	16-675	233-536
800 and 900..... 600K and 700K.....	TSX-534	Gas	- - - - -	EAF-9510-D	286-1229	16-634	233-536
600 and 700.....	TSX-551	Dist	- - - - -	EBE-9510-D	286-1140	16-634	233-536
800 and 900.....	TSX-577	Dist	- - - - -	EBE-9510-D	286-1177	16-634	233-536
800-4 wheel, 900 tricycle.	TSX-580	Gas	- - - - -	EAE-9510-D	286-1095	16-675	233-536
600-4 wheel, 700 tricycle.	TSX-593	Gas	TSX-706	EAF-9510-E	286-1096	16-634	233-536
800 and 900.....	TSX-662	Gas	- - - - -	310015	286-1183	16-654	233-595
	TSX-692	Gas	- - - - -	310746	286-1185	16-634	233-595
	TSX-706	Gas	- - - - -	EAF-9510-G	286-1163	16-634	233-595

◆The repair kit includes the throttle shaft, float valve and seat assembly, and the gasket kit.
§ The flange gasket can be supplied separately. Specify the carbureter number when ordering.

BASIC SUBASSEMBLIES

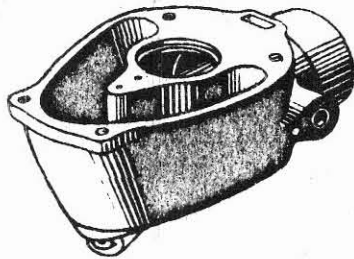

CARBURETER BODY ASSEMBLY

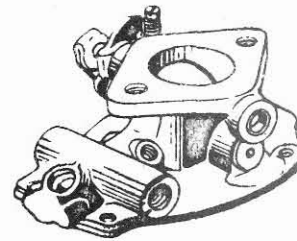

THROTTLE BODY & SHAFT ASSEMBLY

Carbureter Number	Marvel-Schebler Part Number	Ford Part Number	Carbureter Number	Marvel-Schebler Part Number	Ford Part Number
TSX-500	10-3564	8N-99537	TSX-500	227-1293	EAE-9515-A
TSX-534	10-3965	9N-9511-A	TSX-534	227-1319	- - - - -
TSX-551	10-3737	- - - - -	TSX-551	227-1319	- - - - -
TSX-577	10-4000	- - - - -	TSX-577	227-1436	- - - - -
TSX-580	10-3744	- - - - -	TSX-580	227-1334	- - - - -
TSX-593	10-3769	- - - - -	TSX-593	227-1343	- - - - -
TSX-662	10-4085	- - - - -	TSX-662	227-1481	- - - - -
TSX-692	10-4053	- - - - -	TSX-692	227-1467	- - - - -
TSX-706	10-4100	- - - - -	TSX-706	227-1343	- - - - -

Marvel-Schebler Products Division, Borg-Warner Corporation, Decatur, Illinois, U. S. A.

Ref. No.	Part Name	Marvel-Schebler Part Number	Ford Part Number	TSX-500	TSX-534	TSX-551	TSX-577	TSX-580	TSX-593	TSX-662	TSX-692	TSX-706
2	Throttle Shaft Assy	13-1030	EAE9581A	1	-	-	-	1	-	-	-	-
2	Throttle Shaft Assy	13-1109	EAF9581B	-	1	1	1	-	1	-	1	1
2	Throttle Shaft Assy	13-1193	-	-	-	-	-	-	-	1	-	-
3	Throttle Valve	14-175	9N9585A	1	-	-	-	1	-	-	-	-
		14-246	-	-	1	1	1	-	1	-	1	1
		14-273	-	-	-	-	-	-	-	1	-	-
4	Screw-Throttle Stop (8-32x3/4)	15-42	31093S	1	1	1	1	1	1	1	1	1
5	Screw-Nozzle Plug	15-409	357378S	1	1	1	1	1	1	-	1	1
6	Screw-Throttle Valve (6-32x1/4)	15-483	-	-	-	-	-	-	-	2	-	-
7	Screw-Choke Valve (6-32x1/4)	15-483	-	-	-	-	-	-	-	2	-	-
8	Screw-Throttle Body to Bowl	15-A82	43368S	4	4	4	4	3	3	-	3	3
		15-A85	-	-	-	-	-	-	-	4	-	-
6	Screw-Throttle Valve (4-40x1/4)	15-A91	8N99597	2	2	2	2	2	2	-	2	2
7	Screw-Choke Valve(4-40x1/4)	15-A91	8N99597	2	2	2	2	2	2	-	2	2
9	Screw-Body to Bowl (12-24x1 1/8)	15-A206	-	-	-	-	-	1	1	-	1	1
10	Gasket-Float Valve Seat	16-4	9N9564	1	1	1	1	1	1	1	1	1
11	Gasket-Main Nozzle	16-28	EAE9608A	1	1	1	1	1	1	-	1	1
12	Gasket-Needle seat & Bowl Plug	16-47	354680S	-	-	-	-	-	-	1	-	-
13	Gasket-Body to Bowl	16-80	9N9519	1	1	1	1	1	1	-	1	1
11	Gasket-Nozzle	16-456	-	-	-	-	-	-	-	1	-	-
14	Gasket-Power Needle	16-491	9N9563	1	1	1	1	1	1	-	1	1
13	Gasket-Throttle Body to Bowl	16-A41	-	-	-	-	-	-	-	1	-	-
15	Spring-Throttle Stop Screw	24-262	9N9589	1	1	1	1	1	1	1	1	1
16	Spring-Choke Relief Valve	24-292	-	-	-	-	-	-	-	1	-	-
17	Spring-Idle Needle	24-340	9N9578	1	1	1	1	1	1	1	1	1
16	Spring-Choke Relief Valve	24-425	9N9560	1	1	1	1	1	1	-	1	1
17	Spring-Power Needle	24-A1	9N9540C	1	1	1	1	1	1	-	1	1
18	Spring-Choke Return	24-A40	9N9539	1	1	1	1	1	1	-	1	1
		24-A107	-	-	-	-	-	-	-	1	-	-
19	Spring-Float Support	24-A332	311528	-	-	-	-	-	-	-	1	1
20	Choke Shaft Assy	26-766	EAE9546A	1	-	-	-	1	-	-	-	1
		26-799	EAE9546A	-	1	1	1	-	1	-	1	-
		26-829	-	-	-	-	-	-	-	1	-	-
21	Choke Valve	27-539	9N9549	1	-	-	-	1	-	-	-	-
		27-548	-	-	-	-	-	-	-	1	-	-
		27-573	EAF9549B	-	1	1	1	-	1	-	1	1
22	Float Assy	30-600	9N9550A	1	1	1	1	1	1	-	1	1
		30-739	-	-	-	-	-	-	-	1	-	-
23	Float Shaft	32-16	-	-	-	-	-	-	-	1	-	-
		32-27	9N9558A	1	1	1	1	1	1	-	1	1
24	Seat-Power Needle	36-293	-	-	-	-	-	-	-	1	-	-
25	Idle Adjusting Needle	43-33	9N9541	1	1	1	1	1	1	1	1	1
26	Power Adjusting Needle	43-632	EAE9565A	1	1	1	1	1	1	-	1	1
		43-722	-	-	-	-	-	-	-	1	-	-
26	Power Adjusting Needle & Seat	43-723	-	-	-	-	-	-	-	1	-	-

Ref. No.	Part Name	Marvel-Schebler Part Number	Ford Part Number	TSX-500	TSX-534	TSX-551	TSX-577	TSX-580	TSX-593	TSX-662	TSX-692	TSX-706
27	Packing-Power Needle	44-51	- - - - -	-	-	-	-	-	-	-	-	-
28	Packing-Throttle Shaft.....	44-63	8N9622	1	1	1	1	1	1	-	1	1
29	Packing-Choke Shaft.....	44-63	8N9622	-	-	-	-	-	-	1	-	-
29	Packing-Choke Shaft	44-66.....	8N9689	1	1	1	1	1	1	-	1	1
28	Packing-Throttle Shaft.....	44-68.....	- - - - -	-	-	-	-	-	-	1	-	-
30	Venturi 23/32".....	46-476.....	9N9586A	1	-	-	-	1	-	-	-	-
		46-A12	- - - - -	-	-	-	-	-	-	1	-	-
		46-A128	- - - - -	-	1	-	-	-	1	-	-	1
		46-A132	- - - - -	-	-	1	1	-	-	-	-	-
		46-A160	- - - - -	-	-	-	-	-	-	-	1	-
31	Nozzle.....	47-270.....	EAE9530A	1	-	-	1	1	-	-	-	-
		47-393.....	EAF9530A	-	1	-	-	-	1	-	-	1
		47-414	- - - - -	-	-	1	-	-	-	-	-	-
		47-462	- - - - -	-	-	-	-	-	-	1	-	-
		47-463.....	- - - - -	-	-	-	-	-	-	-	1	-
32	Idle Jet	49-165.....	9N9596	1	1	1	1	1	1	1	1	1
33	Retainer-Throttle Packing	55-231	9N9591	1	1	1	1	1	1	-	1	1
34	Retainer-Choke Packing	55-231	9N9591	-	-	-	-	-	-	1	-	-
		55-243	9N9695	1	1	1	1	1	1	-	1	1
33	Retainer-Throttle Packing.....	55-261	- - - - -	-	-	-	-	-	-	1	-	-
35	Retainer-Power Needle Packing	55-285	- - - - -	-	-	-	-	-	-	1	-	-
36	Cup-Throttle Shaft Plug.....	55-358	- - - - -	-	-	-	-	-	-	1	-	-
37	Pin-Throttle Stop.....	62-167	9N9575	1	1	1	1	1	1	-	1	1
38	Pin-Choke Stop.....	62-167	9N9575	1	1	1	1	1	1	-	1	1
38	Pin-Choke Stop.....	62-252.....	- - - - -	-	-	-	-	-	-	1	-	-
39	Fuel Inlet Fitting	67-514.....	9N9533	1	1	1	1	-	-	-	-	-
40	Washer-Power Needle	78-299	356211S8	1	1	1	1	1	1	-	1	1
36	Plug-Throttle Shaft Hole.....	80-169	8N9941	1	1	1	1	1	1	-	1	1
41	Plug-Choke Shaft Hole	80-169	8N9941	-	-	-	-	-	-	1	-	-
42	Plug-Idle Drilling Hole	80-171	8N9974B	1	1	1	1	1	1	1	1	1
43	Studs-Mounting Flange	83-413	88371S8	2	2	2	2	2	2	-	2	2
		83-441	- - - - -	-	-	-	-	-	-	2	-	-
44	Drain Cock.....	87-3A	8N99537	1	-	1	1	-	-	-	-	-
45	Plug-Bowl Drain.....	99-7	358043S8	-	1	-	-	1	1	1	1	1
46	Bracket-Float Support Spring	136-110	311531	-	-	-	-	-	-	1	1	1
47	Float Valve & Seat Assy	233-536	9N9564	1	1	1	1	1	1	-	-	-
		233-543	- - - - -	-	-	-	-	-	-	1	-	-
		233-595.....	311529	-	-	-	-	-	-	-	1	1

TEMPORARY SERVICE PARTS LIST - INSERT IN THE PROPER SECTION OF YOUR MANUAL

Model 800 Alcohol Tractor		Ford Motor Co. #312778	Model TSX-771
PART NO.	QUAN.	Ford #	PART NAME
10-4214	1		Carbureter Body Assembly
13-1257	1		Throttle Shaft & Lever Assembly
14-246	1		Fly - Throttle (18°)
15-42	1	31093-S	Screw (#8-32 x 3/4) (Throttle Stop)
15-409	1	357378-S	Screw (Nozzle Plug)
15-A82	3	43368-S	Screw (#12-24 x 5/8 Sems Fill. Hd.) (Throttle Body to Bowl)
15-A91	2	8N-99597	Screw (#4-40 x 1/4 Bind. Hd.) (Throttle Fly)
15-A91	2	8N-99597	Screw (#4-40 x 1/4 Bind. Hd.) (Choke Fly SEMS)
15-A206	1	43415-S	Screw (#12-24 x 1 1/8 Sems Fill. Hd.) (Throttle Body to Bowl)
16-4	1	9N-9564	Gasket - Float Valve Seat
16-28	1	EAE-9608-A	Gasket - Main Nozzle
16-80	1	9N-9519-B	Gasket - Throttle Body to Bowl
16-491	1	9N-9563	Gasket - Main Adjusting Needle
16-634	1		Gasket Assembly (Service)
24-262	1	9N-9589	Spring - Throttle Stop Screw
24-340	1	9N-9578	Spring - Idle Needle
24-A1	1	9N-9540-C	Spring - Main Adjusting Needle
24-A40	1	9N-9539-A	Spring - Choke Return
24-A332	1		Spring - Float Support
26-799	1		Choke Shaft & Lever Assembly
27-573	1		Fly Choke Assembly
30-600	1	9N-9550-A	Float & Lever Assembly
32-27	1	9N-9558-A	Shaft - Float Lever
43-33	1	9N-9541	Needle - Idle Adjusting
43-632	1	EAE-9565-A	Main Adjusting Needle Assembly
43-642	1		Main Adjusting Needle Assembly Complete
44-63	1	8N-9622	Packing - Throttle Shaft
44-66	1	8N-9689	Packing - Choke Shaft
46-A145	1		Venturi - (23/32 Diameter Throat)
47-A11	1		Nozzle
49-429	1		Jet - Idle
55-231	1		Retainer - Throttle Shaft Packing
55-243	1		Retainer - Choke Shaft Packing
62-167	2	9N-9575	Pin - Throttle Stop-1 Choke Stop-1
78-299	1	356211-S8	Washer - Plain (Main Adjusting Needle)
80-167	1		Plug - Choke Shaft Hole
80-171	1	8N-9974-B	Plug - Idle Drilling
80-169	1	8N-9941	Plug - Throttle Shaft Hole
83-413	2	88371-S8	Stud - 5/16-18 x 5/16-24 (Flange)
99-21	1	358043-S8	Plug - Bowl Drain
227-1616	1		Throttle Body Assembly
233-595	1	9N-9564	Float Valve, Seat & Gasket Ass'y. (Matched)
286-1254			Repair Kit

TEMPORARY SERVICE PARTS LIST - INSERT IN THE PROPER SECTION OF YOUR MANUAL

Ford Motor Company

TSX-813

PART NO.	QUAN.	PART NAME
10-4247	1	Carbureter Body Assembly
13-1258	1	Throttle Shaft Assembly
14-273	1	Fly - Throttle (15°)
15-85	1	Screw (#8-32 x 7/8) Fill. Head (Throttle Adjusting)
15-483	4	Screw (#6-32 x 1/4) "SEMS" Bind Hd. (Choke Fly-2) (Thr. Fly-2)
15-A85	4	Screw (#12-24 x 3/4) "SEMS" Fill. Hd. (Thr. Body to Bowl)
16-4	1	Gasket - Float Valve Seat
16-47	1	Gasket - Main Adjusting Needle Seat & Bowl Plug
16-456	1	Gasket - Nozzle
16-A41	1	Gasket - Throttle Body to Bowl
16-654	1	Gasket Set
24-262	1	Spring - Throttle Stop Screw
24-292	1	Spring - Choke Flapper
24-340	1	Spring - Idle Needle
24-A107	1	Spring - Choke Return
24-A332	1	Spring - Float Support
26-829	1	Choke Shaft Assembly
27-548	1	Choke Fly Assembly
30-739	1	Float & Lever Assembly
32-16	1	Shaft - Float
36-293	1	Main Adjusting Needle, Seat & Bowl Plug
43-33	1	Needle - Idle Adjusting
43-722	1	Main Adjusting Needle Assembly
43-723	1	Main Adj. Needle, Seat Packing & Packing Ret. Assembly
44-51	1	Packing - Main Adjusting Needle
44-63	1	Packing - Choke Shaft
44-68	1	Packing - Throttle Shaft
46-A12	1	Venturi - 15/16" Throat
47-A6	1	Main Nozzle
49-165	1	Idle Jet
55-231	1	Retainer - Choke Shaft Packing
55-261	1	Retainer - Throttle Shaft Packing
55-285	1	Retainer - Main Adjusting Packing Needle
55-358	1	Cup - Throttle Shaft Plug
62-167	1	Pin - Throttle Stop
62-252	1	Pin - Choke Stop
80-169	1	Plug - Choke Shaft
80-171	1	Drill Plug - Name Plate in Idle Plug Hole
99-7	1	Bowl Plug
136-110	1	Bracket - Float Spring Support
227-1716	1	Throttle Body Assembly
233-595	1	Float Valve, Seat & Gasket Assembly Matched
286-1345	1	Repair Kit

